

## Digital Video Recorder

Quick Reference Guide

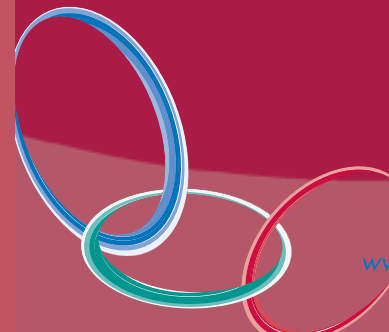
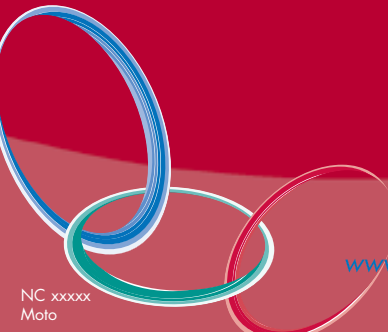

# Table of Contents

<b>WELCOME</b> .....	2
<b>SAFETY INSTRUCTIONS</b> .....	3
<b>USING YOUR DVR REMOTE CONTROL</b> .....	4
<b>CONTROLLING LIVE TV</b> .....	5
<b>RECORDING PROGRAMS</b> .....	6
<b>VIEWING SAVED PROGRAMS</b> .....	7
<b>MANAGING SAVED PROGRAMS</b> .....	8
<b>MANAGING SCHEDULED RECORDINGS</b> .....	9
<b>MANAGING SERIES RECORDINGS</b> .....	10
<b>USING TITLE AND KEYWORD SEARCH</b> .....	11
<b>USING THE DVR WITH HDTV</b> .....	12
<b>INSTALLATION DIAGRAMS</b> .....	13-16
<b>FREQUENTLY ASKED QUESTIONS (FAQS)</b> .....	17-18
<b>NOTES</b> .....	19-20

Dear Cox Customer:

Congratulations and thank you for selecting Cox Communications for your Digital Video Recorder (DVR) service. The way you watch TV is about to change, so get ready.

DVR service from Cox gives you complete control of your television viewing by allowing you to watch your favorite shows on your schedule. You will be able to automatically record your favorite programs (no videotapes required). You'll also be able to pause and rewind live TV. With DVR service from Cox, you'll never miss your favorite show again!

Please take a few minutes to familiarize yourself with the functions and features of the DVR service. Because it is so simple to use, you will be recording your favorite programs and controlling live TV right away! Should you have any questions after you've begun using your DVR, please visit our web site or call a customer care representative at the number listed below. We will be happy to answer any questions you may have.

Cox Communications strives to bring our customers the latest in video and broadband technology. The Digital Video Recorder is just one more way Cox is leading the way in digital home entertainment.

Thank you and enjoy your new DVR service.

### Customer Care Representative:

**X-XXX-XXX-XXXX**

**[www.cox.com](http://www.cox.com)**

# Safety Instructions



Your digital cable receiver has been designed to operate reliably in a well-ventilated environment. Please follow these important instructions when positioning and connecting the receiver to your television:

- Position the receiver with at least 2 inches of space on all sides. Do not position the set-top in an enclosed space that would restrict airflow around the unit.
- Do not block any of the slots or openings.
- Do not position the set-top near any external heat source that could raise the temperature around the unit.
- If you must stack the receiver with other electronic devices, place this unit on the bottom.

This receiver contains an internal hard drive similar to those found in personal computers. If you need to move the receiver, you should unplug it from the outlet and wait 10 seconds before moving it.

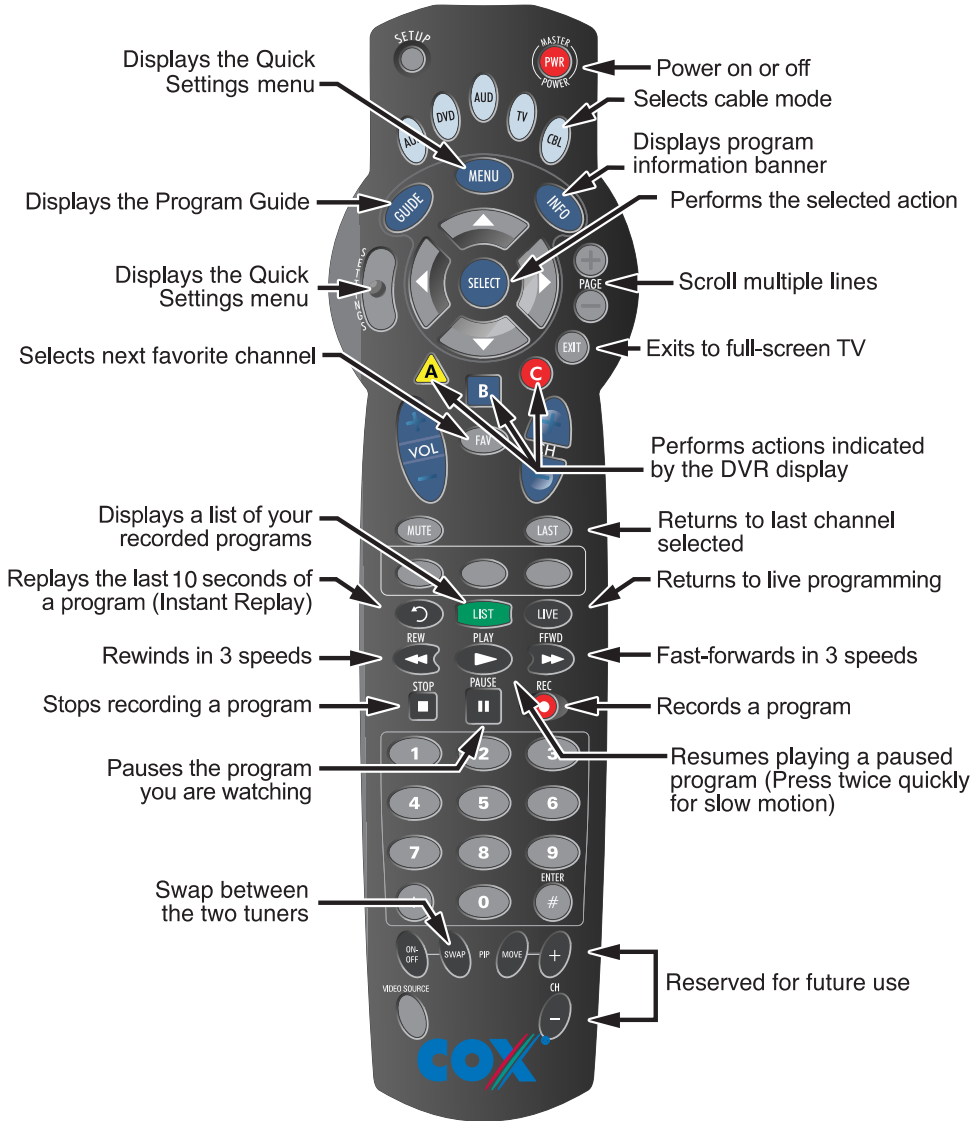

## Controlling Live TV

You can use the remote control buttons to control a live program.

### What you can do:

#### Pause a show

Press

#### Resume playback from pause

Press OR

#### Rewind

Press once (slow speed)  
 Press twice (medium speed)  
 Press three times (rapid speed)

#### Fast forward

Press once (slow speed)  
 Press twice (medium speed)  
 Press three times (rapid speed)

#### Advance one frame

Press , then press

#### Watch video in slow motion

Press twice quickly (within 1/2 second)

#### Resume playback from rewind, fast forward, or slow motion

Press

#### See an instant replay

Press

#### Return to "live" TV

Press

# Recording Programs

There are several ways to record your favorite programs.

## Recording the show you are watching

Press while watching a TV show to access the Recording dialog box

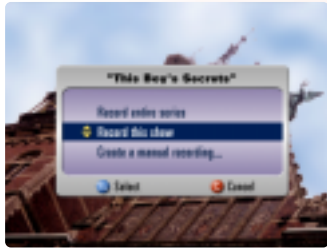

### What you can do:

Record the current TV show

Record entire series

### How to do it:

Select "Record this Show"

Select "Record entire series" Use arrows to set series options (first run vs. repeats, number of saved episodes)

## Scheduling recordings from the Program Guide

Go to the Program Guide by pressing



Schedule a single instance recording

Schedule a Series Recording

Find a program to record X days in the future

Highlight a show and press , then select "Record this show"

Highlight a show and press , then select "Record entire series." Use arrows to set series options (first run vs. repeats, number of saved episodes)

Press the number key representing the number of days into the future you want to record and immediately press key

# Viewing Saved Programs

Programs that have been saved can be accessed at any time from the Saved Shows Display.

To view a saved program, access the Saved Shows Display by pressing



### What you can do:

Find a saved show

Play the highlighted show

### How to do it:

Press OR to highlight a show

Press OR Press , then select "Play", "Play from Beginning" or "Resume Playback" from the dialog box

Once you are viewing a saved program, you can control how you watch the show.



Pause a show

Resume playback from pause

Rewind a show

Fast forward

Advance one frame

Watch video in slow motion

Resume playback from rewind or fast forward

See an instant replay

Return to "live" TV

Erase a show

Press

Press OR

Press once (slow speed)  
Press twice (medium speed)  
Press three times (rapid speed)

Press once (slow speed)  
Press twice (medium speed)  
Press three times (rapid speed)

Press , then press

Press twice quickly (within 1/2 second)

Press

Press

Press

Press , then press (Stop and erase)

# Managing Saved Programs

By default saved programs will be automatically erased as space is needed for new recordings, or they can be saved until you erase them manually.

Go to the Saved Shows Display by pressing **LIST**



**What you can do:**

**Find a saved show**

**How to do it:**

Press **UP** OR **DOWN** to highlight a show

**Erase a show**

Highlight a show; press **SELECT**; Select "Erase"

**Save a show until manually erased**

Highlight a show; press **SELECT**; Select "Save until manually erased"

**Allow a show to be erased automatically**  
(Note—This is default setting.)

Highlight a show; press **SELECT**; Select "Save until space is needed"

**Keep a show longer**

Highlight a show; press **SELECT**; Select "Keep longer..."  
Press **UP** OR **DOWN** to increase or decrease the life span of the highlighted show; Press **SELECT** (Note: shows that are positioned higher on the list will be erased later)

Saved shows can be automatically erased to make room for new shows, or saved until you erase them.

- Indicates that a show will be saved until it is manually erased.
- Indicates that a show is expected to be automatically erased soon.
- Indicates that a show is expected to be automatically erased very soon.

# Managing Scheduled Recordings

Your Scheduled Recordings list lets you see which upcoming programs are scheduled to be recorded. It also lets you cancel upcoming recordings.

Go to the Scheduled Recordings list by pressing **LIST**, then pressing **B**



**What you can do:**  
**Find an upcoming scheduled recording**

**How to do it:**  
Press **UP** OR **DOWN** to select a scheduled recording

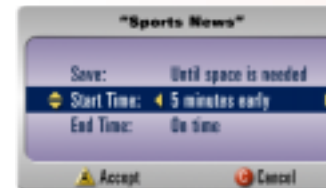

**Modify start or end time**

Press **SELECT**  
Select "Record Options"  
Use arrows to set start time or end time



**Cancel an upcoming scheduled recording**

Press **SELECT**  
Select "Cancel Recording"  
Press **SELECT**  
Press **Y** to confirm

# Managing Series Recordings

You can view all the series you have scheduled to record and assign priorities to resolve potential recording conflicts.

Go to the Series Manager by pressing **LIST**, then pressing **C**.



**What you can do:** Find a Series Recording  
**How to do it:** Press **UP** OR **DOWN** to highlight a Series Recording

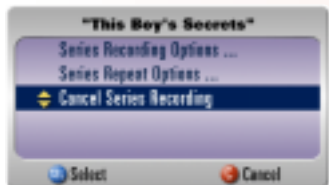

**What you can do:** Cancel a Series Recording  
**How to do it:** Press **SELECT**  
 Select "Cancel Series Recording"

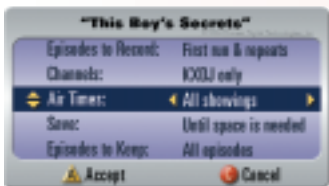

**What you can do:** Edit Series Recording Options  
**How to do it:** Press **SELECT** and select "Series Recording Options"  
 Use arrows to set series options (first run vs. repeats, number of saved episodes)



**What you can do:** Set the recording priority  
**How to do it:** Select the series, press **SELECT**; select Series Recording Priority; Use **UP** OR **DOWN** to re-order the assigned priorities to the programs

*(Note: recordings positioned higher on the list will be recorded first in the event of a conflict)*

# Using Title/Keyword Searches

You can quickly search for your favorite programs by title, actor or keyword.

## Search for shows by Title or Keyword

Go to the Program Guide by pressing **GUIDE** and press **C** to access Search; highlight and select 'Titles' or 'Keywords'



**What you can do:** Search for shows by Title  
**How to do it:** Enter a title using the on-screen keyboard; use the arrow key to highlight each letter and **SELECT** to enter



Press **RIGHT** to go to the Search Results List, then scroll up or down to highlight a show or Series Header (shows belonging to series are grouped under Series Headers)

Highlight a Series Header and press **SELECT** to view individual episodes, or **RECORD** to record the entire series

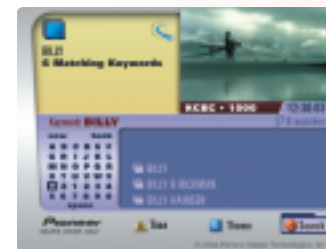

**What you can do:** Search for shows by Keyword  
**How to do it:** Enter a keyword (i.e. actor, director, or subject) using the on-screen keyboard; use the arrow keys to highlight each letter and **SELECT** to enter

Press **RIGHT** repeatedly to go to the Search Results list, then scroll up or down to highlight a show or Keyword Header (related shows are grouped under Keyword Headers)

Highlight a Keyword Header and press **SELECT** to view related shows, or **RECORD** to create a Keyword Series Recording

# Using the DVR with HDTV

If you have a High-Definition TV, you will need to set up your DVR so that it provides video to your HDTV in picture formats that your television supports. As a default your DVR is programmed to display all programs in 480i picture format. Most HDTV's display high-definition programs in either 720p or 1080i. To set up your DVR to work with your HDTV you will need to use the following procedures.

Consult your HDTV owner's manual to determine the supported HD picture formats. Test your DVR by pressing the **GUIDE** button while the DVR is powered on. If you cannot see the Guide, use the following instructions:

- 1 Ensure that the DVR is turned on (you will see video).
- 2 Press **PWR** and then the **MENU** button twice. This will deactivate any scheduled recordings and bring you into the Basic User Settings screen.
- 3 Press the **DOWN** button once.
- 4 Press the **RIGHT** until you can view the Basic User Settings menu on the screen.
- 5 Confirm that the setting displayed matches the best setting supported by HDTV as specified in your HDTV Owner's Manual. If not, repeat step 4.
- 6 Press **PWR** to exit the Basic User Settings screen.
- 7 Press **PWR** to turn on your DVR and reactivate any scheduled recordings.

If you can see the Guide, use the following instructions:

- 1 Ensure that the DVR is turned on (Press **GUIDE** ).
- 2 Press the **MENU** button.
- 3 Press the **▲** button for "More Settings". This will bring up the General Settings menu.
- 4 Scroll down to "Output Formats".
- 5 Use the **RIGHT** button and navigate through the settings to match the best resolution supported by your HDTV.
- 6 Press the **▲** button to select and verify that the selection listed next to Output Formats is correct. If it is not, repeat step 5. Press **EXIT** button to return to normal operations.

## Front of DVR

The DVR has 12 keys and an LED display. Use the keys to perform basic functions such as access the interactive program guide and navigate menus. The following drawing describes each feature and its use:

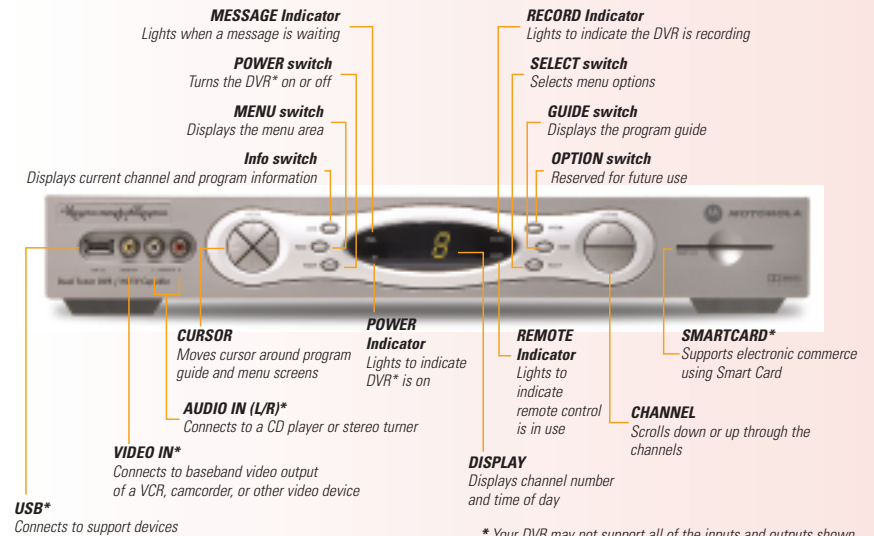

## Back of DVR

The back panel of the DVR consists of three types of interfaces — audio, video and data. The following drawing describes each connection and its use.

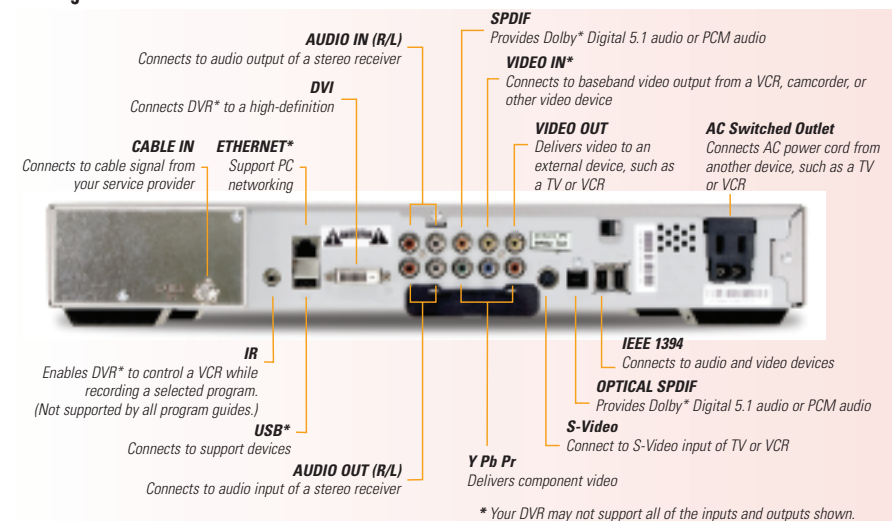

### Connecting the DVR to a Standard Definition TV and VCR

This diagram should be used if you intend to connect the DVR to a standard definition TV only, OR, a standard definition TV along with a VCR.

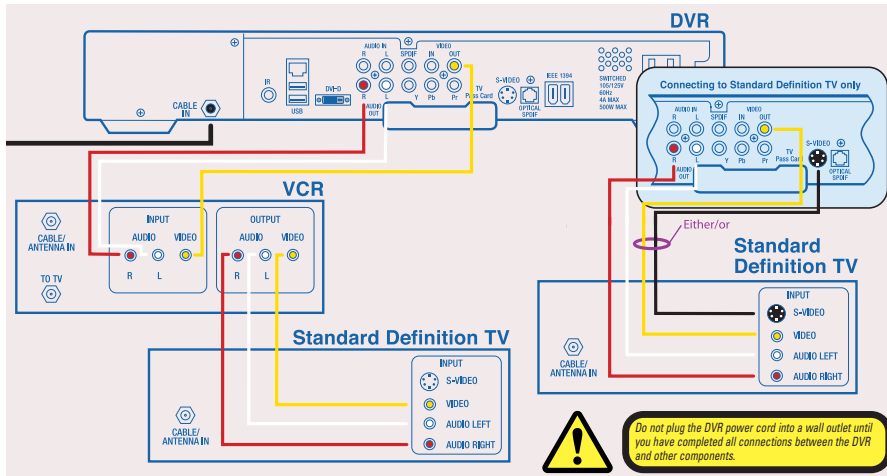

### Connecting the DVR to a High-Definition TV – Video Options

This diagram shows the High-Definition video connection between your DVR and your High-Definition television (HDTV). This is the primary diagram for providing HD video and should be done prior to the following audio configurations.

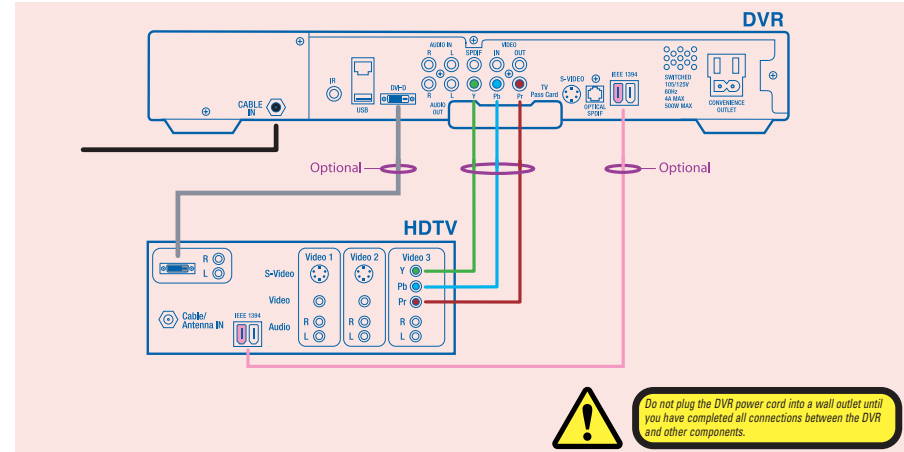

### Connecting the DVR to a Standard Definition TV, A/V Receiver and VCR

This diagram should be used when incorporating an A/V receiver with a standard definition TV and VCR.

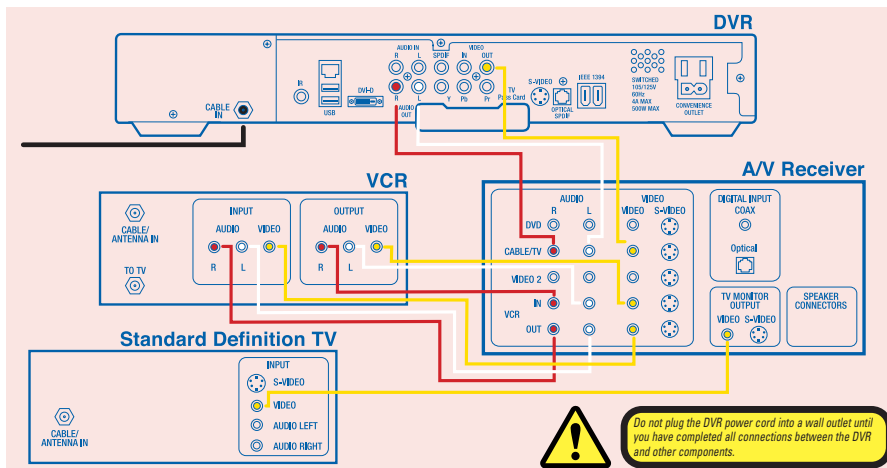

### Connecting the DVR to a High-Definition TV – Audio Options

This diagram shows the primary audio connection from your DVR to your HDTV. You should use this configuration only if your HDTV has built-in speakers and you do not intend to include a stereo or home theater receiver in your configuration.

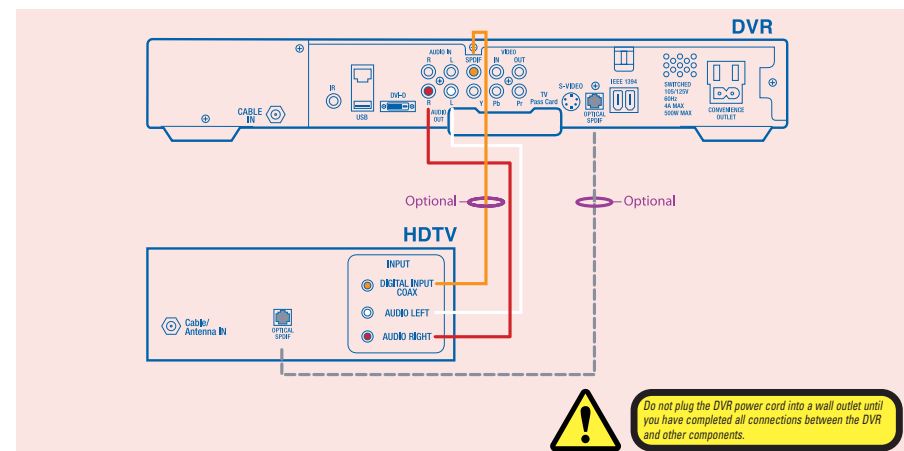

## Connecting the DVR to an A/V Receiver – Audio Only

This diagram should be used if you intend to use an A/V receiver for your audio connections.

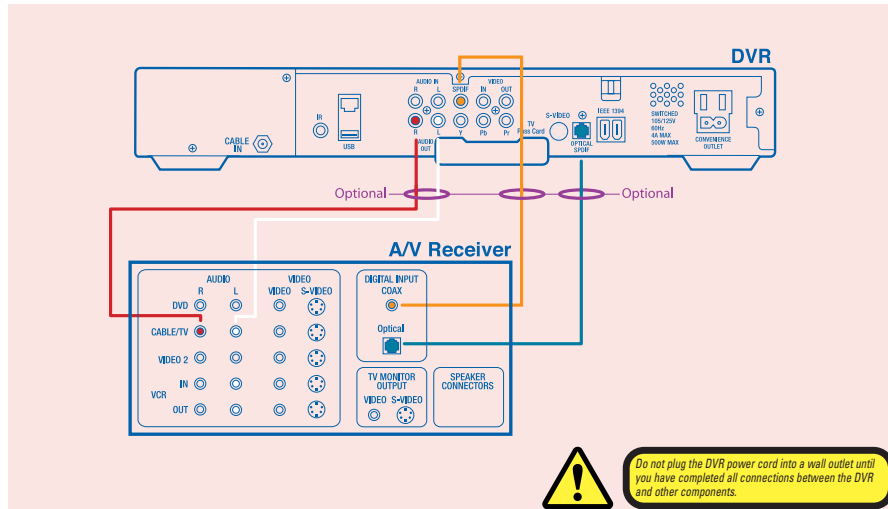

## Frequently Asked Questions

**Q. Will my DVR allow me to watch and record High-Definition (HD) programs?**

A. Yes! You can receive HD programs on your DVR system. You can even record HD programs. However, you will need an HD television or HD monitor to view the programs in high definition.

**Q. Can Pay-Per-View (PPV) or Entertainment-on-Demand (EOD) programs be recorded?**

A. PPV programs may be recorded after they have been purchased. Once a PPV program has been recorded, you can use VCR-like controls. Currently, EOD programs cannot be recorded on your DVR.

**Q. How do I know when my DVR's hard disk drive is getting full?**

A. By default, your DVR system automatically erases programs when disk space is needed to record new programs, so you don't need to worry about making space for new programs.

**Q. How do I prevent my DVR from automatically erasing programs when it needs more space?**

A. To make sure a specific program is not automatically erased when more space is needed, use the recording options in the Saved Shows screen and set the program to "save until manually erased."

**Q. How many recordings can I schedule?**

A. The DVR can store up to 60 hours of programming on the hard drive. The amount of programming varies depending on whether the show is in high-definition, or standard definition digital or analog. High-definition programs will take up more hard drive space than digital or analog programs.

**Q. After I schedule a recording, can I adjust the start or end time of the recording?**

A. Yes! You can have the recording begin up to 10 minutes early, or end up to 3 hours later than the scheduled broadcast. You can change this setting in the Record Options dialog in the Guide, the Saved Shows, Scheduled Recordings or Series Manager screens.

**Q. Can I watch a recording-in-progress from the beginning of the program?**

A. Yes! If you are recording a live program, you can view any portion of it up to the "live" point.



